

Single Feed Kit - 4100/5100 Series

The Steffes Comfort Plus systems have built-in circuit breakers. They are factory configured to be field connected to multiple line voltage circuits. If single feed to the element and blowers/control circuits is desired, the single feed kit is available to allow the system to be powered with a one, larger line voltage circuit. Contact the factory for ordering details.

Return Air Plenum - 4100 Series

A factory-built return air plenum is available for the 4100 series systems but is ordered as a separate accessory. This plenum incorporates a tray for placement of a heating/cooling coil which must get set in the return ductwork when interfaced to a heat pump. The return air plenum connects directly to the 4100 series systems for either a right-to-left or left-to-right airflow pattern.

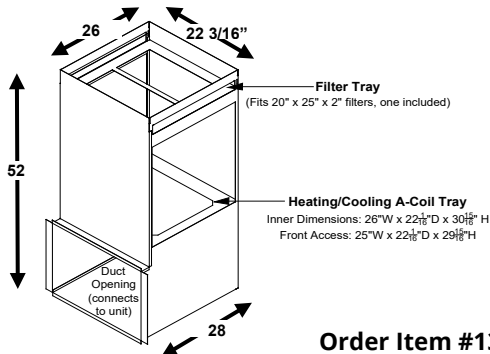

Order Item #1301550 - 70 lbs

Down Flow Kit - 4100 Series

The Steffes Comfort Plus 4100 series forced air systems are designed for upflow supply air discharge. In applications where downflow air discharge is desired, Steffes offers a kit that provides the ability to connect the supply air plenum in a manner that directs the air downward. (Order Item # 1301578). In downflow configuration, the furnace must be installed in a fashion that allows access to the supply blower's plenum cover. It is recommended to elevate the furnace a minimum of 10" to achieve this access. An elevation stand (Order Item #1301585) is available from the factory.

Elevation Stand - 4100/5100 Series

Some applications (such as garages) may require that the heating appliance be elevated in order to meet building codes. The Steffes Comfort Plus stand elevates the 4100 or 5100 series Comfort Plus system 18". This stand is shipped as a kit and requires field assembly.

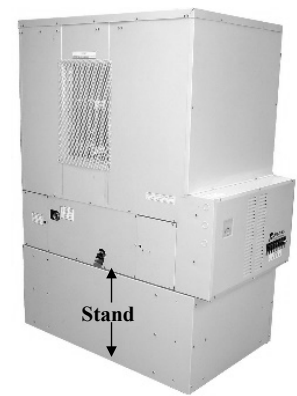

Order Item #1301585 - 76 lbs

Static Heat Recovery Unit - 5100 Series

During operation of the Comfort Plus Hydronic system, some heat from the brick core storage will radiate through its outer panels. If the system is located in an area with minimal heating requirements, such as a garage or utility room, the static heat recovery unit can maximize the system's efficiency by transferring this static heat to a more desirable location. The static heat recovery unit connects directly to the Comfort Plus Hydronic system to interface with the internal controls of the system for automatic operation.

NOTE: In applications where the air handler is already being utilized, the static heat recovery unit would not be used.

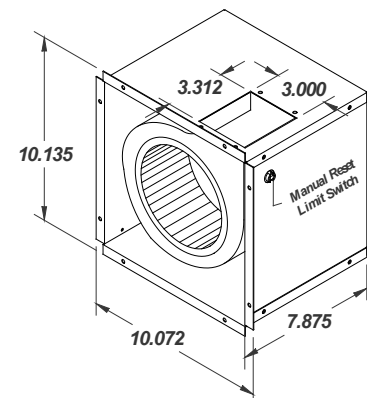

Order Item #1302110 - 11

Air Handler – 5100 Series

The Steffes Air Handler is an optional device designed to interface with the Comfort Plus Hydronic (5100 Series) furnace to allow it to provide forced air heating as a stand-alone furnace or as a supplement to other ducted heating systems such as a heat pump. When used with a heat pump, it allows the Comfort Plus Hydronic furnace to serve as the back-up heat source and provide comfort modulation. Heat pumps can be operated to much lower temperatures allowing for full utilization of their efficiency while optimizing system performance. A duct sensor constantly monitors outlet air temperature and modulates the precise amount of stored off-peak heat needed to eliminate cool and uncomfortable discharge air temperatures typically associated with heat pump systems during cool outdoor temperatures. The air handler will also direct the heat lost statically through the furnace's outer panels into the ductwork for delivery to the living space (automatic static heat recovery). The internal controls of the Comfort Plus Hydronic furnace automatically regulate the operation of the air handler. The Steffes Air Handler includes a return plenum, supply air blower, water coil, and air filter. It is painted and fully insulated.

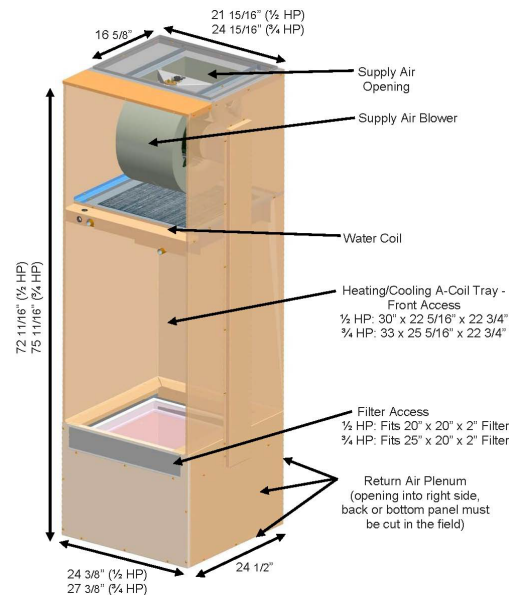

Order Item	Description	Weight
#1302132	½ HP EON Blower	200 lbs
#1302134	¾ HP EON Blower	225 lbs

CONFIGURATIONS AVAILABLE:

- ½ HP variable speed blower with 60,000 BTU/hr water coil (accommodates most 1.5 to 4 ton heating/cooling systems)
- ¾ HP variable speed blower with 90,000 BTU/hr water coil (accommodates most 3 to 5 ton heating/cooling systems)

Primary Loop Kit – 5100 Series



Order Item #1302115 – 37

The Comfort Plus Hydronic system requires a primary water loop which serves to regulate heat transfer from the unit's heat exchanger. To minimize installation time and costs for field design and engineering of this loop, Steffes Corporation offers a primary loop kit. The kit contains the components generally installed with hydronic heat systems.

FEATURES:

- Includes a 5-gallon diaphragm type expansion tank, Taco 007 pump (circulator), air separator, air vent, pressure gauge, and pump connection conduit and fittings.
- Contains the appropriate valves to bleed air from the system during filling along with automatic purge during system operation and draining.
- Incorporates isolation flanges for quick and easy servicing of the primary loop pump (circulator).
- Offers troubleshooting isolation between the heating system and secondary zones.